

DYNAFLAIR

ROLLING CLOSURE BARREL ASSEMBLY DETAIL

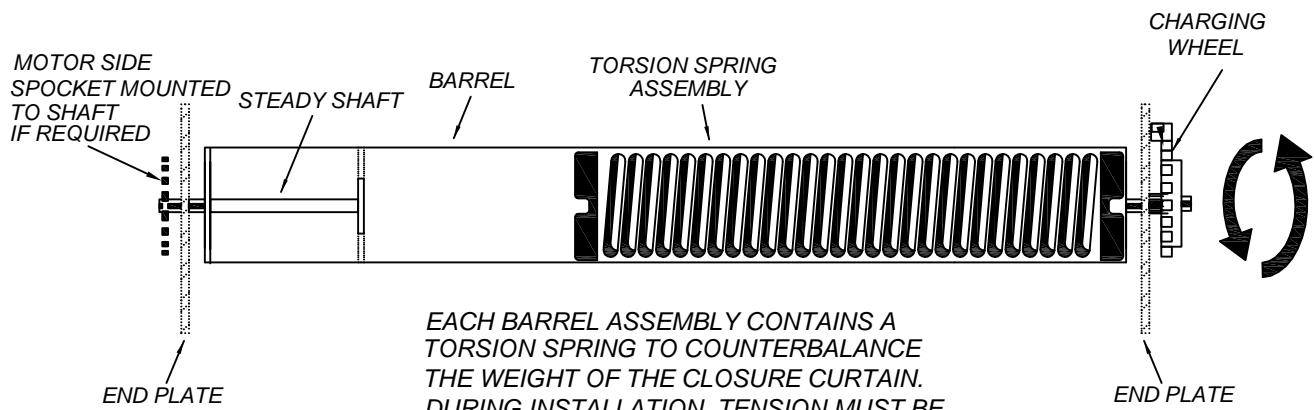

EACH BARREL ASSEMBLY CONTAINS A TORSION SPRING TO COUNTERBALANCE THE WEIGHT OF THE CLOSURE CURTAIN. DURING INSTALLATION, TENSION MUST BE WOUND OR "CHARGED" INTO THE SPRING SO THAT THE UP-DOWN ACTION OF THE CLOSURE IS RELATIVELY EFFORTLESS.