

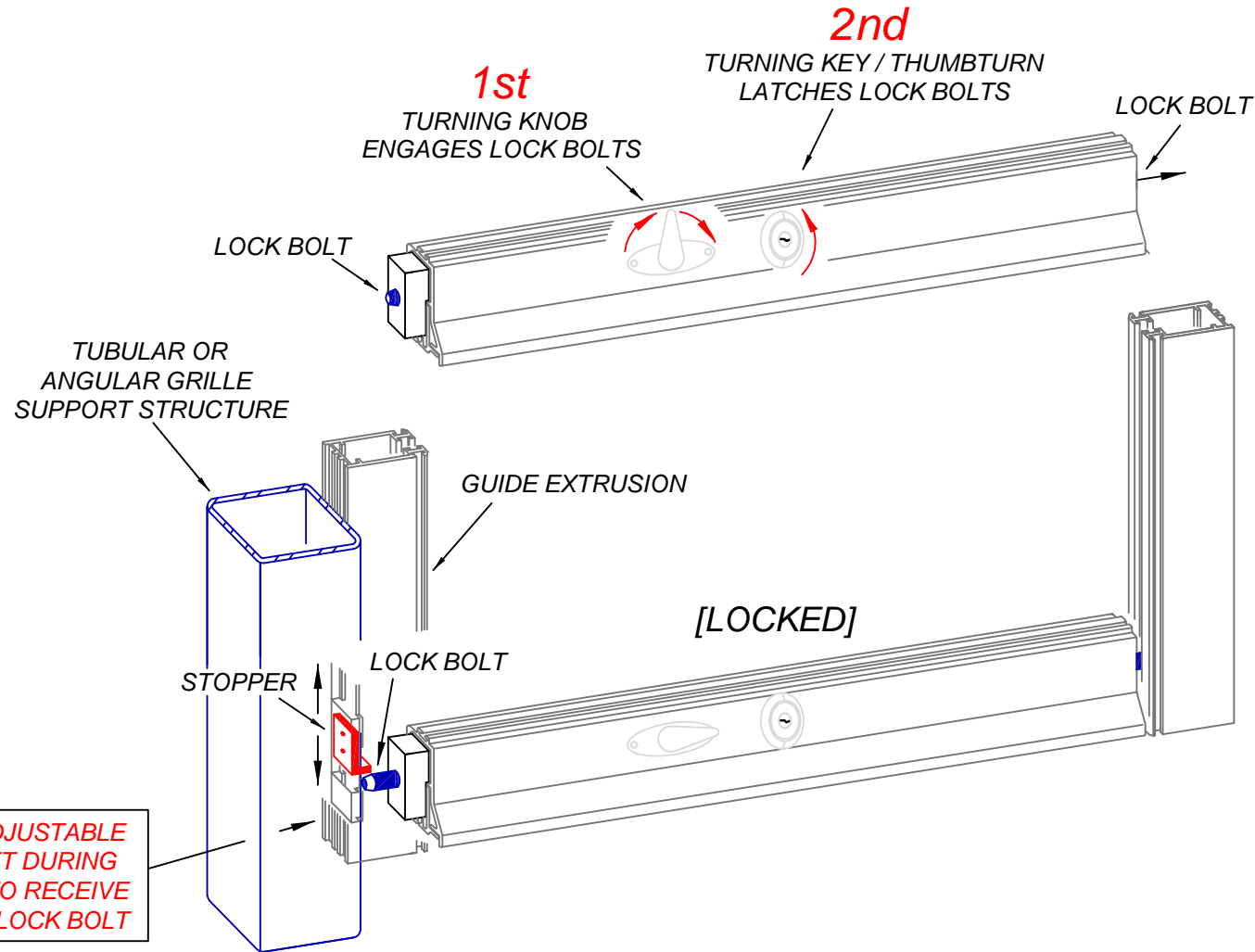

ROLLING CLOSURE BOTTOM LOCK BAR



LOCK CYLINDER REQUIREMENT

STANDARD 5, 6 OR 7 PIN
MORTISE CYLINDER



STANDARD OR
"ADAMSRITE"
TYPE CAM